

IMPORTANCE OF SOIL THERMAL CHARACTERISTIC FOR UNDERGROUND POWER CABLES



CABLE RATING CALCULATIONS ARE CONDUCTED USING AMPACITY PROGRAMS THAT REQUIRE VARIOUS INPUT PARAMETERES

THE CABLE TYPE AND CHARACTERISTIC (components, extruded solid dielectric, self-contained FF, HPGF, etc.)

TYPE OF INSTALLATION (tre-foil, flat-formation, pipe-type, directly buried, in HDD, in duct-bank)

**AND THE ENVIRONMENT IN WHICH THEY ARE INSTALLED
(soil and backfill – EXTERNAL THERMAL ENVIRONMENT)**

CABLES ARE MANUFACTURED UNDER A CONTROLLED ENVIRONMENT AND TO EXACT SPECIFICATIONS

TESTS ARE ALSO CONDUCTED IN FACTORY TO ASSURE QUALITY AND PERFORMANCE

EXTERNAL THERMAL ENVIRONMENT

Input parameters required for rating:

1. Temperature

- **Earth ambient temperature at burial depth**
 - **Surface or air temperature**

These temperatures are NOT in our control and therefore actual values must be used in the rating calculations

2. Soil Thermal Characteristic (why?)

- **because all cables have a limiting temperature rating for a safe and efficient operation (short-term emergency and long-term continuous). If exceeded, it will shorten the life of the cable or can result in FAILURE**

Example: Seasonal temperature change with depth

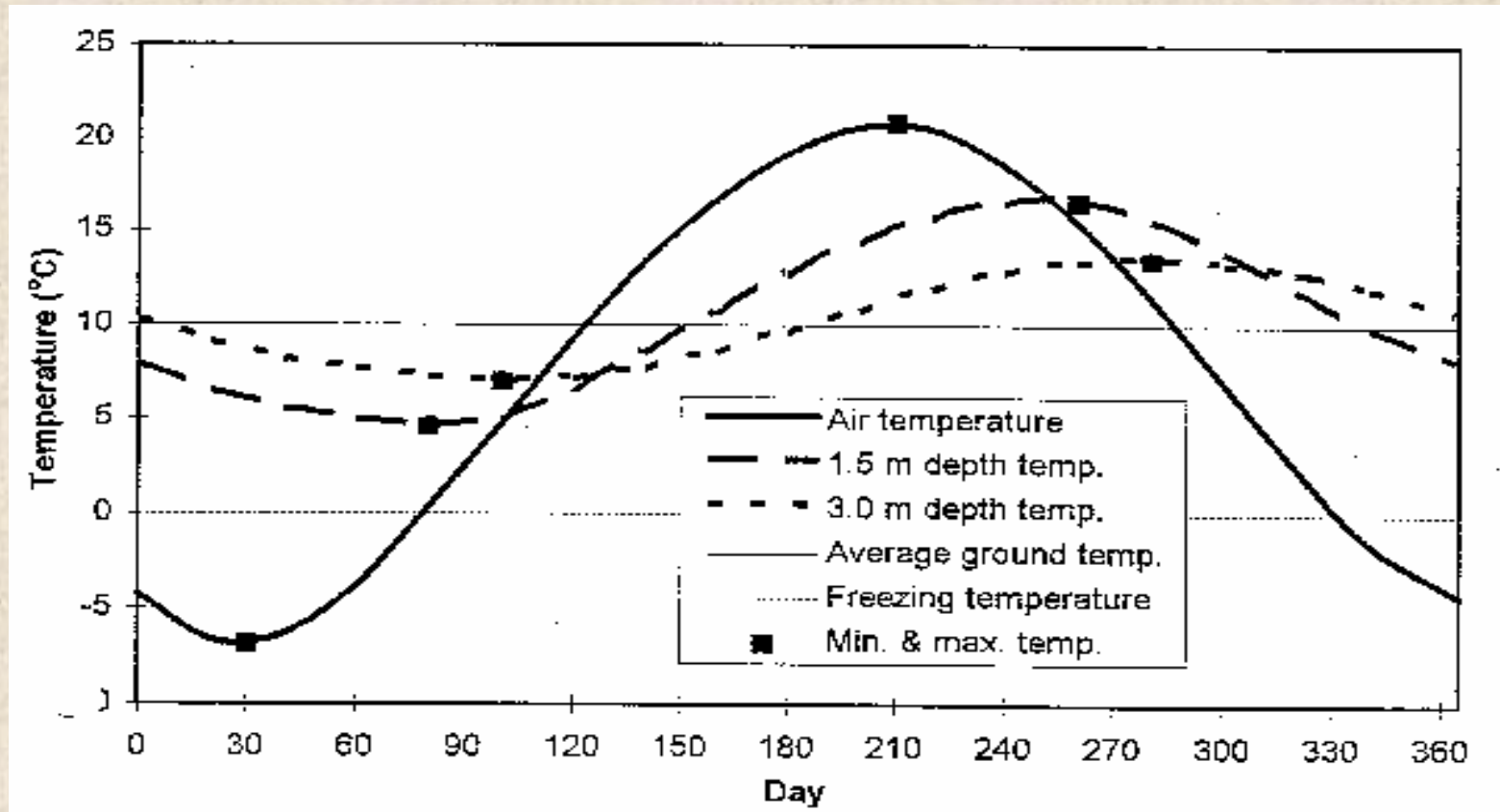

**Typical for a location at 40° latitude (Toronto, Canada).
For locations in the tropics, the shape of the curves will be similar but
the amplitudes will be shallower with closer average temperatures**

SOIL THERMAL RESISTIVITY

The Cable Thermal Circuit (pipe-type cable) is represented by an Electrical Analog; showing values for Thermal Resistances of various components

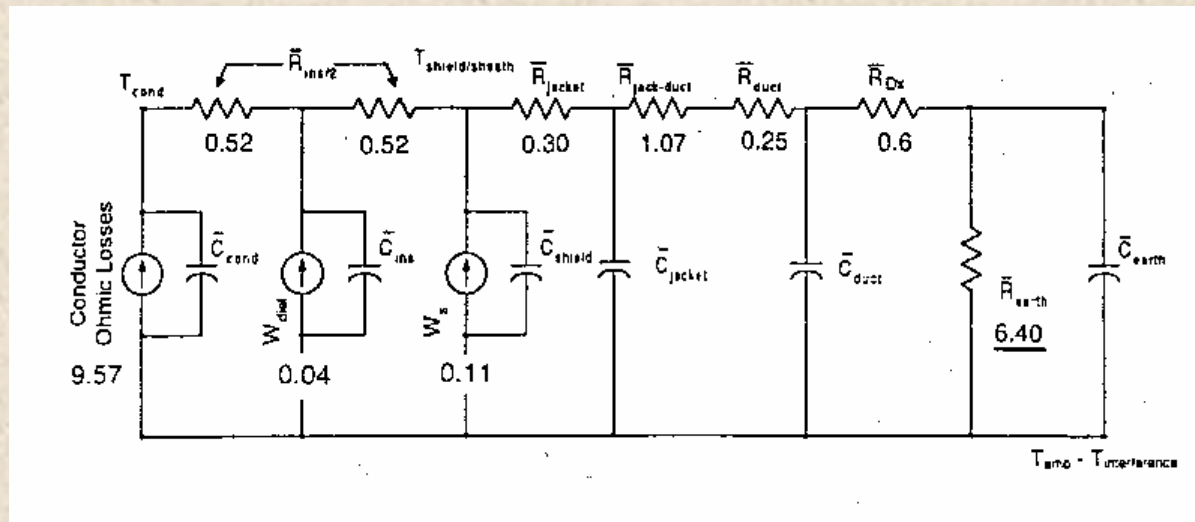

The earth gives the largest single thermal resistance and has the greatest variability – with distance along the route, and even with time. It can easily vary threefold on a specific circuit, and the cable must be rated for the worst case condition

Effect of Soil Thermal Resistivity on Cable Ampacity

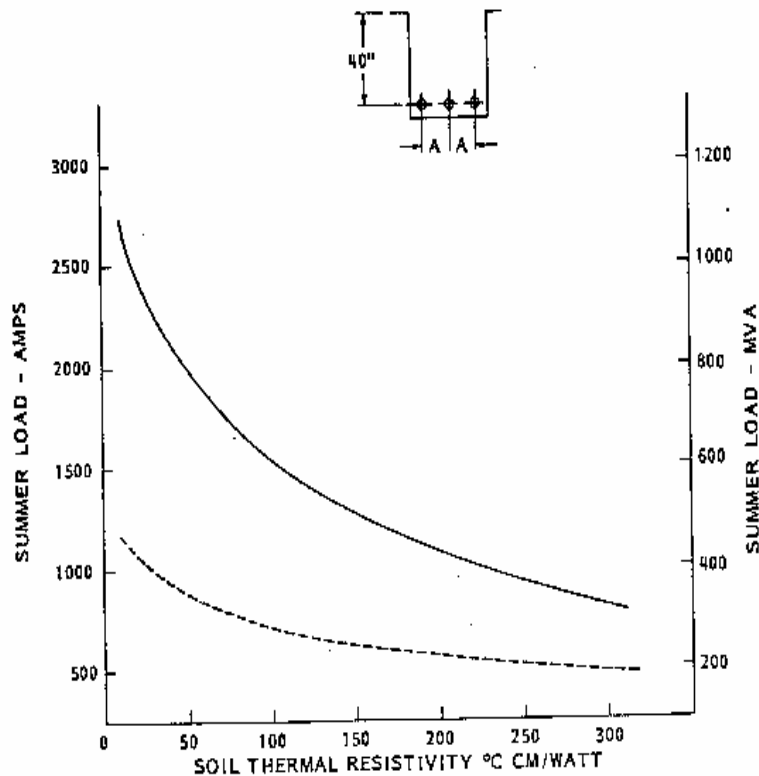

— 230 KV, 2750 MCM, DIRECT BURIED OIL-FILLED CABLE
CONDUCTOR TEMP. 85°C, SOIL AMBIENT 20°C
A = 12"

- - - 138 KV, 750 MCM, DIRECT BURIED OIL-FILLED CABLE
CONDUCTOR TEMP. 85°C, SOIL AMBIENT 20°C
A = 6"

Directly buried solid-dielectric cables

- cables are buried directly in native soil without the presence of any special thermal backfill
- actual ampacity numbers vary but relationship holds true for any cable system and voltage (why?)

because it is **ONLY** the heat generated by the cables ($I^2 R$) that affects the soil thermal resistivity **NOT the voltage**

- number of options can be considered to lower the thermal resistivity of the cable environment

Effective thermal resistivity = Native Soil + Backfill

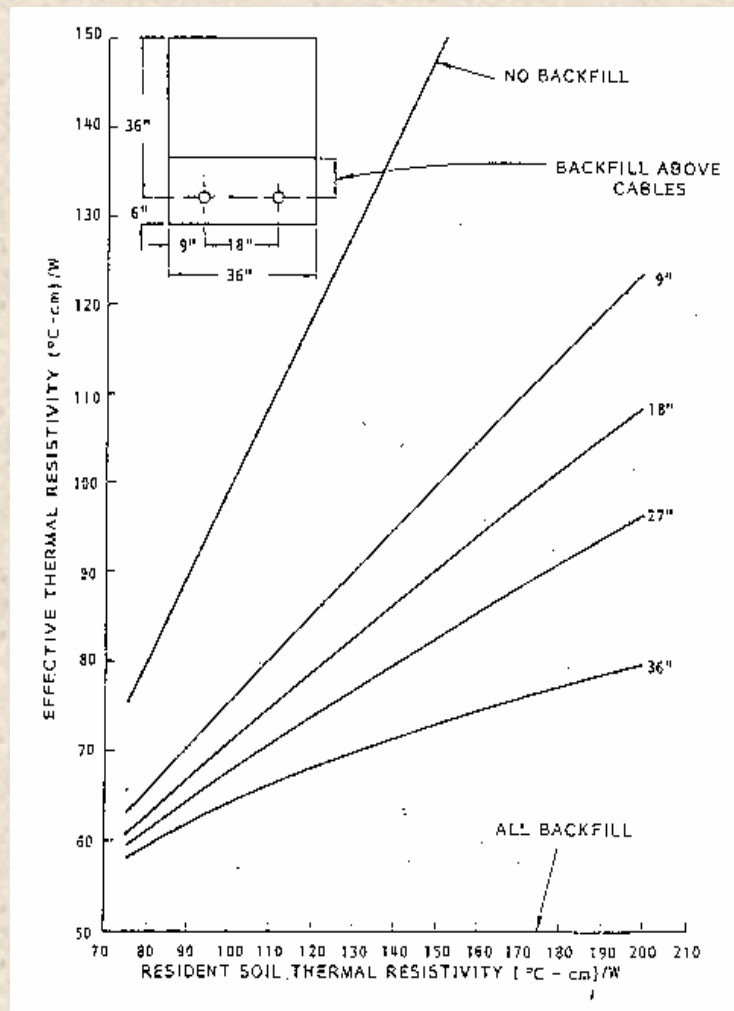

In order to lower the overall thermal resistivity, an envelope of an imported material commonly referred to as controlled backfill or corrective backfill is installed around the cables. The thermal characteristic of this material and the thickness of the envelope will result in an overall lower thermal resistivity. This new value of thermal resistivity - composite resistivity or effective resistivity is used in the ampacity calculations

Most computer based ampacity programs are capable of handling numerous variables and parameters for native soil, backfill, thickness, trench width, burial depth, spacing, etc.

EXTERNAL THERMAL ENVIRONMENT

Pipe-Type Cable Installation

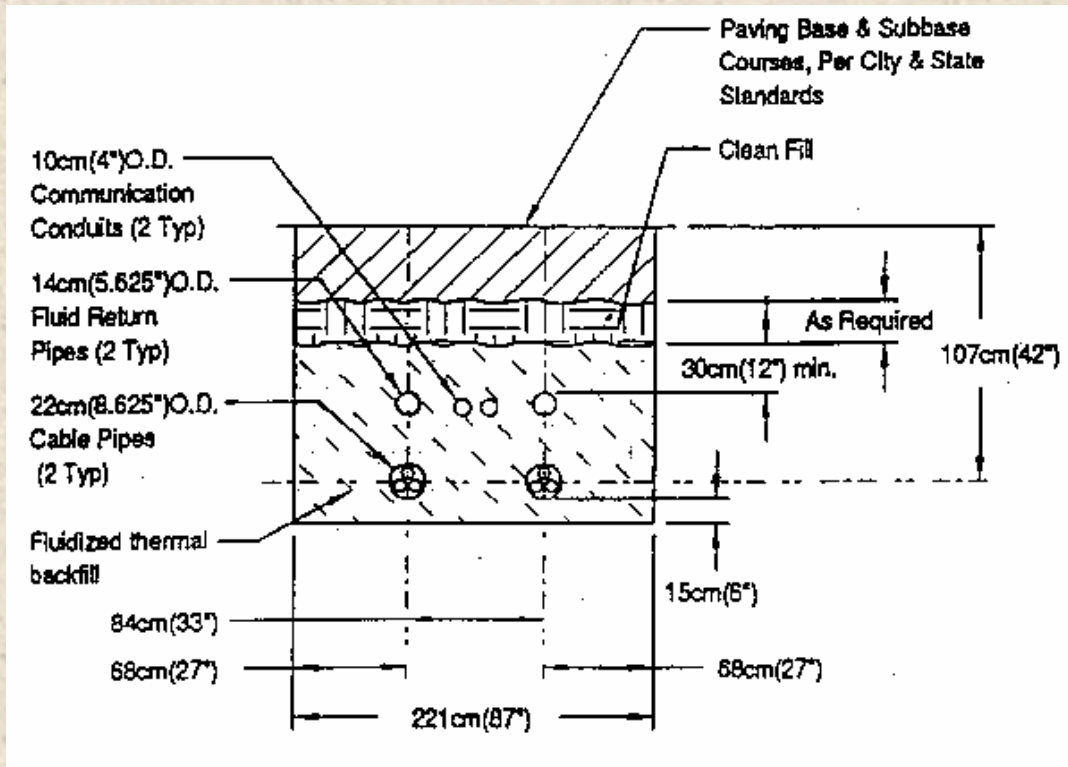

- cables can be treated as heat source
- ambient earth surface as ultimate heat sink
- thermal backfill, native soil & other backfills are the media through which heat is transported - primarily by conduction

Keeping cable temperatures within the design limits under all conditions is the key to heat transfer efficiency and stability of external thermal environment between cables and ground surface

STEADY-STATE RADIAL HEAT FLOW FROM AN UNDERGROUND CABLE

Consider a cylindrical heat source (power cable) in a homogeneous media (soil)

$$q = -2\pi r K \left(\frac{dT}{dr} \right) \quad \text{or}$$

$$\int_{T_2}^{T_1} dT = \frac{q}{2\pi K} \int_{r_2}^{r_1} \frac{dr}{r}$$

The thermal gradients in a radial flow field are inversely proportional to the distance from the heat source

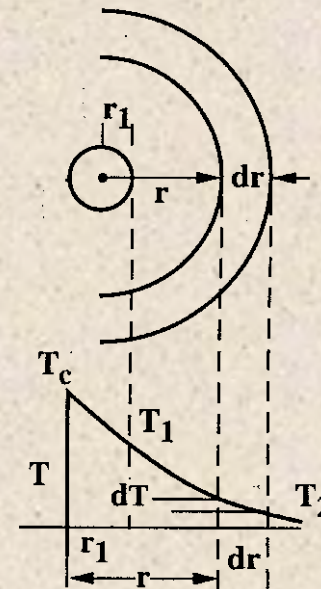

Therefore: thermal resistivity of the material adjacent to cables is very important

FACTORS AFFECTING SOIL THERMAL RESISTIVITY

1. SOIL COMPOSITION

Mineral Type and Content
Organic Content
Chemical Bonding Between Particles

2. TEXTURE

Grain Size Distribution
Grain Shape

3. WATER CONTENT

Degree of Saturation
Porosity

4. DRY DENSITY

Porosity
Solids Content
Inter-particle Contacts
Pore Size Distribution

5. AMBIENT TEMPERATURE

Negligible Effect

6. OTHERS

Solutes – Dissolved Salts and Minerals
Hysteresis – change in water level

SOIL – A COMPOSITE MATERIAL

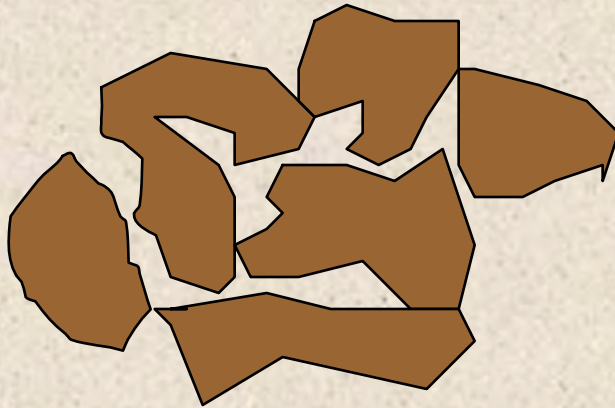

High Thermal Resistivity

Uniform size soil particles (low soil density) provide few contacts for heat conduction

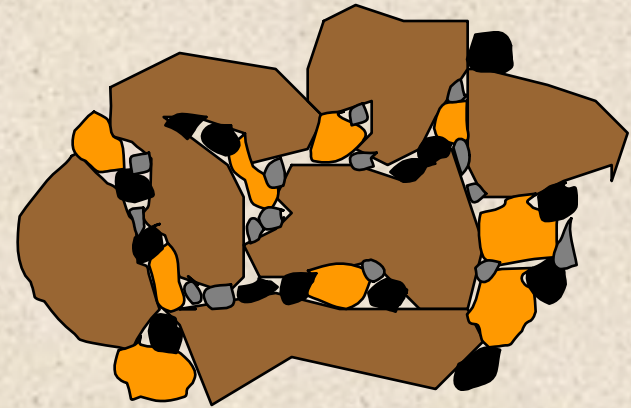

Low Thermal Resistivity

Variety of particle sizes (Well graded) reduces air spaces (high soil density) and provides many contacts for heat conduction

MECHANISM OF HEAT TRANSFER IN SOIL

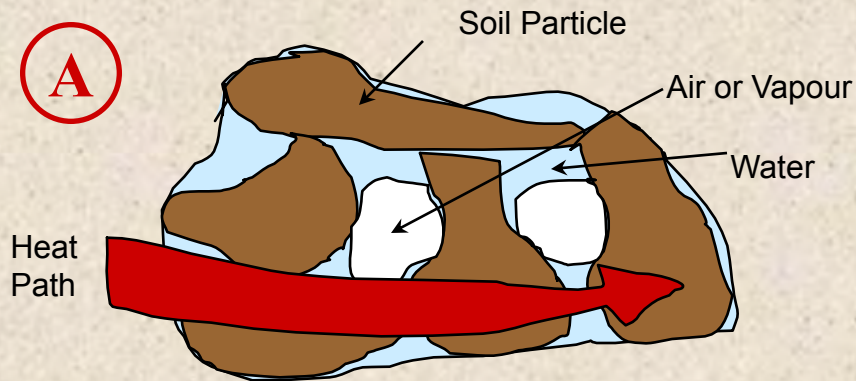

Wet Soil: High water content provides an easy path for heat conduction ("thermal bridges"), therefore the soil thermal resistivity is low.

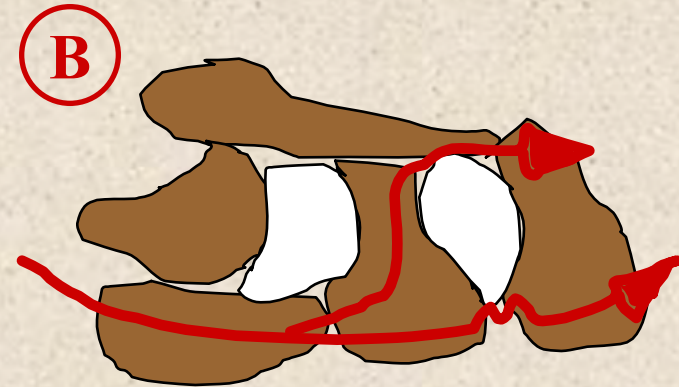

Damp Soil: As soil dries, discontinuities develop in the heat conduction path due to low water content, therefore thermal resistivity increases.

THERMAL DRYOUT CHARACTERISTICS

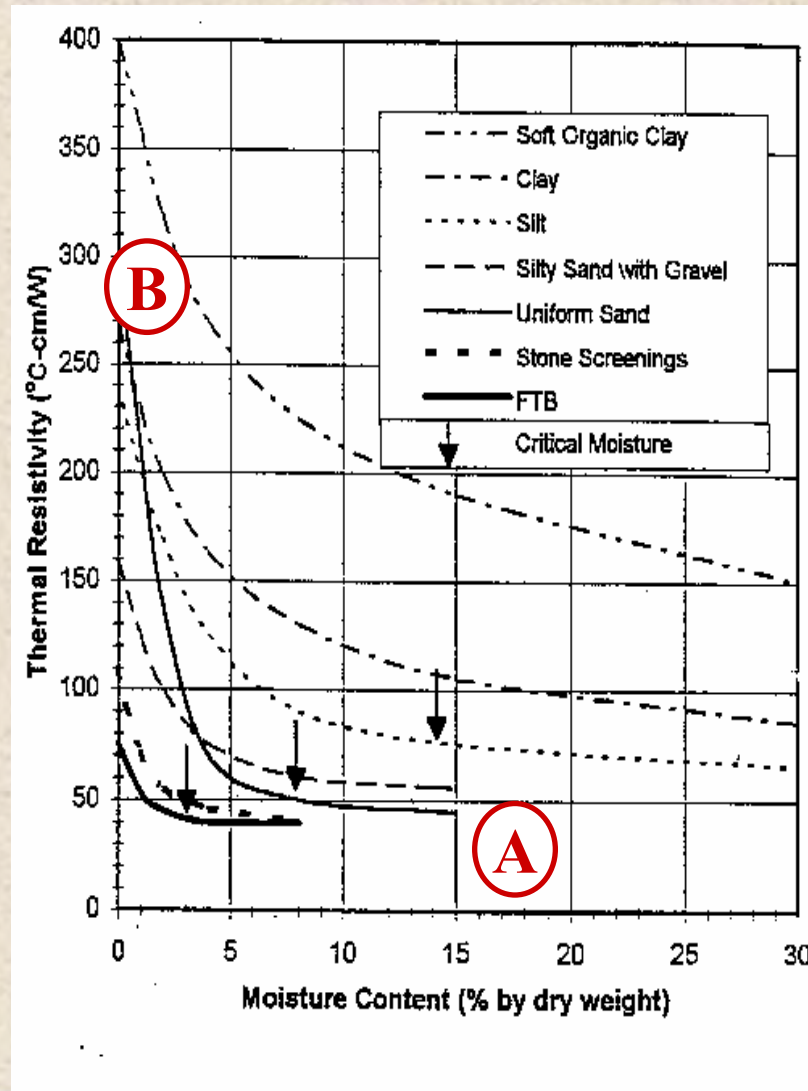

SOIL COMPONENTS

Description	Thermal Resistivity Dry ($^{\circ}\text{C}\text{-cm}/\text{W}$)
Soil Grains	
Quartz	12
Granite	30
Limestone	40
Sandstone	50
Shale (sound)	60
Shale (highly friable)	200
Mica	170
Others	
Ice	45
Water	165
Organics	~ 500
Oil (petroleum)	~ 800
Air	~ 4500

Transient Thermal Needle Test (Thermal Resistivity)

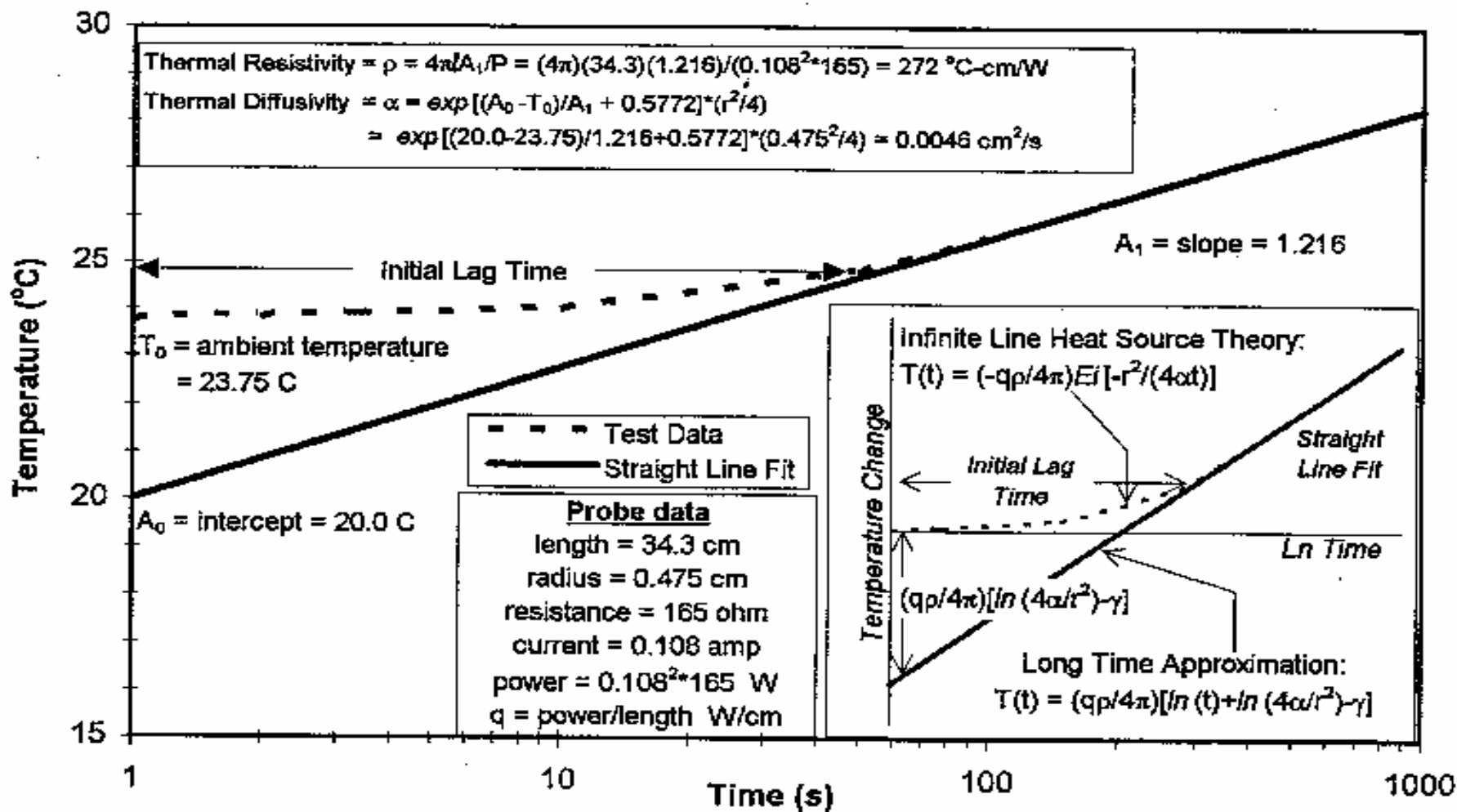

THERMAL DIFFUSIVITY and STABILITY

Thermal Diffusivity (similar to Inertia): Used for transient calculations when there is a load change.

Thermal Stability: Under certain conditions (high and prolonged load) the moisture of the backfill can drop below the 'critical level' and the thermal resistivity may increase above the acceptable level. If not corrected, it can lead to thermal runaway and failure.

ELEMENTS OF A ROUTE THERMAL SURVEY

- **Review and Planning**
- **Soil Boring, sampling and in-situ thermal testing**
- **Laboratory testing**
- **Analysis**
- **Selection of corrective thermal backfill**
- **Quality control/assurance program**

CORRECTIVE THERMAL BACKFILLS

Material that will enhance heat conduction

Select man-made and engineered to meet specific thermal and mechanical performance

Unwashed well-graded sands, stone-dust

Sand-cement blend

Duct-bank concrete

Fluidized Thermal Backfill (FTB)

CORRECTIVE THERMAL BACKFILLS

Types of Thermal Backfills

Native soils if found to be satisfactory

Granular materials

e.g. well-graded sands and stone screenings

Granular soils with additives (binders - CLAY)

Sand-cement mixtures

Fluidized Thermal Backfill (FTB)

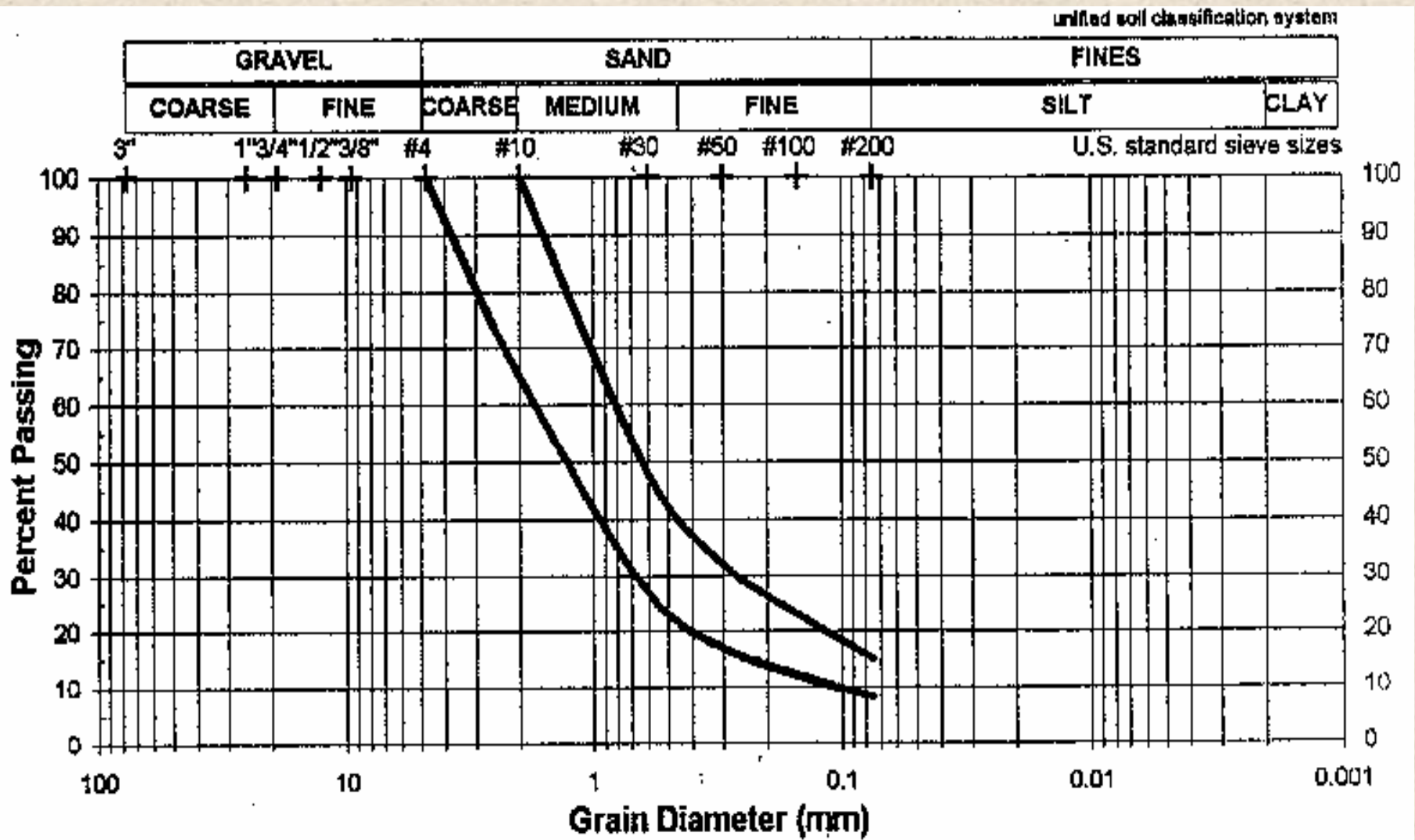

Gradation envelope for a good granular type of thermal backfill

Thank you for pretending to stay awake !!!

Any Questions?

